



OFPPL Multimedia Plate, 10-port

Fiber Drum Storage and Management of Fiber Bend Radius Extends Fiber Life.

Low-Profile Multimedia Promotes Easy Adds and Changes.

Field Configurable Providing Optimum Application Flexibility.



FEATURES

- Accepts Hubbell **XCELERATOR™** jacks and multimedia Audio/Video connectors.
- Up to 4-port capacity.
- Downward positioning of fiber termination protects patch cords by exiting to the bottom and side.
- Compatible with UTP, STP, coax and fiber.

Hubbell Premise Wiring's OFPPL multimedia plate provides extensive multimedia capabilities in a low profile package. The OFPPL multimedia housing accommodates 3 SC duplex or 6 ST-style or 3 LC Quad **OPTIchannel™** fiber adapters. In addition, there are 4 keystone openings for Hubbell's **XCELERATOR™** jacks or Audio/Video connectors. UTP jacks and other copper connectors are positioned in a unique low-profile 45° orientation off the right side.

The OFPPL provides fiber storage and 606 station labeling ability.

SPECIFICATIONS

- ◆ UL Listed File #129878.
- ◆ CSA Certified File LR80837.
- ◆ High-impact housing: UL 94V-0 flame retardant thermoplastic.
- ◆ Color: Office White.
- ◆ Dimensions: 6.5"H x 5.5"W x 1.25"D.

DIMENSIONS

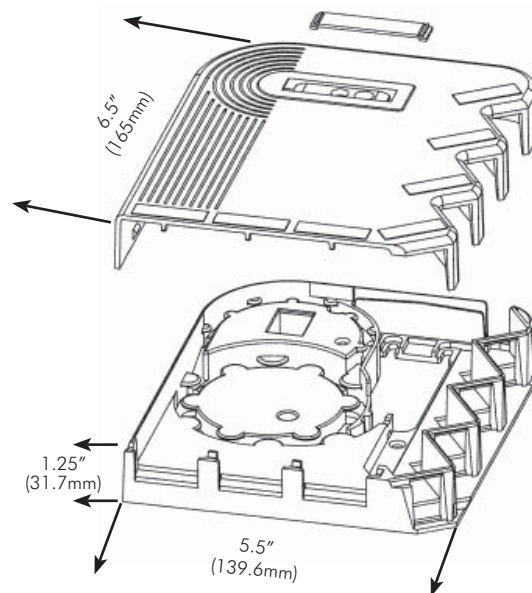

STANDARDS/LISTINGS/VERIFICATIONS

- UL and cUL listed.
- ANSI/TIA/EIA-606A station labeling capability.



OFPL Multimedia Plate



Order Information

Description	Catalog No.
Office white housing, cover and mounting accessories	OFPL
OFP Bracket with 2 ST couplers SM/MM	OFBST2

NOTE: SC duplex and LC Quad connectors mount directly to the OFPL base.

ACCESSORIES

XCELERATOR™ Jacks, Category 6 and 5e

Category	Catalog No.
Category 5e	HXJ5EXX
Category 6	HXJ6XX

XX = Color:
 'AL' = Almond 'OW' = Office White
 'B' = Blue 'OR' = Orange
 'BK' = Black 'P25' = Purple*
 'EI' = Electric Ivory 'R' = Red
 'GL25' = Gold* 'TI' = Telco Ivory
 'GY' = Gray 'W' = White
 'GN' = Green 'Y' = Yellow
 * 25-packs only.



Patch Cords, Category 6 and 5e

Category	Catalog No.
Category 5e	PCX5EXX*
Category 6	PCX6XX**

XX = Standard Color:
 'B' = Blue; 'BK' = Black;
 'GY' = Gray; 'Y' = Yellow
 For other colors replace color designation with one of the following:
 OR = Orange, R = Red, GN = Green, P = Purple, W = White

* = Standard Length: '01'=1'; '03'=3'; '05'=5'; '07'=7'; '10'=10'; '15'=15'; '20'=20';
 '25'=25'; '30'=30'; '35'=35'; '40'=40'; '45'=45'; '50'=50'; '55'=55'; '60'=60';
 '75'=75'; '100'=100'
 ** = Standard Length: '03' = 3'; '06' = 6'; '08' = 8'; '10' = 10'; '12' = 12'; '16' = 16';
 '20' = 20'



Audio/Video Connectors

Description (Office White)	Catalog No.
Blank Module	SFB10
F-Type Coupler Bulkhead F/F	SFFX
RCA Solder Coupler (Red)	SFRCR
S-Video F/F Coupler (Black)	SFSVBK
SC Simplex, SM/MM	SFSC
ST Style, SM/MM	SFST



* Consult the Full Line Catalog (pages B8-B11) for a complete listing of Hubbell's family of Audio/Video Connector options and colors.

UTP Cable, SPEEDGAIN® Category 5E, 4-Pair



Color	Catalog No. Spool	Catalog No. Riser REELEX*	Catalog No. Plenum Spool	Catalog No. Plenum REELEX*
Blue	C5EPSRB	C5EPRRB	C5EPSPB	C5EPRPB
Gray	C5EPSRGY	C5EPRRGY	C5EPSPGY	C5EPRPGY
White	C5EPSRW	C5EPRRW	C5EPSPW	C5EPRPW
Yellow	C5EPSRY	C5EPRRY	C5EPSPY	C5EPRPY

* REELEX is licensed and patented by Windings Inc.

Hubbell Labeling Solutions*

Face Plate Labels, white adhesive	XPLFPA10W
Face Plate Labels, white paper	XPLFP10W
Face Plate Labels, clear adhesive	XPLFPA10C
Port Icon Labels, white adhesive	XPLIPA10W
Port Icon Labels, clear adhesive	XPLIPA10C
Pre-Printed Icon Label Booklets (5-packs)	
Icon Labels, clear adhesive with black text	XPICONS
Icon Labels, clear adhesive with white text	XPICONSW

* Contact our website at www.hubbell-premise.com for our unique Labeling Software.

UTP Cable, NEXTSPEED® Category 6, 4-Pair



Color	Catalog No. Spool	Catalog No. Riser REELEX*	Catalog No. Plenum Spool	Catalog No. Plenum REELEX*
Blue	C6SRB	C6RRB	C6SPB	C6RPB
Gray	C6SRGY	C6RRGY	C6SPGY	C6RPGY
White	C6SRW	C6RRW	C6SPW	C6RPW
Yellow	C6SRY	C6RRY	C6SPY	C6RPY

* REELEX is licensed and patented by Windings Inc.



Hubbell Premise Wiring

HUBBELL INCORPORATED (Delaware)
 14 Lord's Hill Road • Stonington, CT 06378-0901 • (860) 535-8326 • 800-626-0005
 Fax: (860) 535-8328 • Internet site: <http://www.hubbell-premise.com>

Worldwide Locations

Hubbell Premise Wiring, Asia Pacific	852-2836-7131	Fax: 852-2836-7132	Hubbell Premise Wiring, Latin America	305-408-4501	Fax: 305-408-8201
Hubbell Canada Inc.	905-839-1138	Fax: 905-839-9108	Hubbell de Mexico, S.A. de C.V.	(5255) 9151-9999	Fax: (5255) 9151-9989
Hubbell Premise Wiring, Central America	506-309-4158	Fax: 506-260-1616	Hubbell Premise Wiring, Middle East	971-4-393-4192	Fax: 971-4-393-4194
Hubbell Premise Wiring, China	8621-6309-0119	Fax: 8621-6309-0122	Hubbell-Taian Co., Ltd., Taiwan	886-2-2522-1862	Fax: 886-2-2522-1872
Hubbell Premise Wiring, Colombia	571-245-8940	Fax: 571-340-0925	Hubbell Premise Wiring, Turkey	90-216-313-5016	Fax: 90-216-414-8148
Hubbell Premise Wiring, Europe	44-01283 500500	Fax: 44-01283 500400	Hubbell Premise Wiring, Venezuela	58-416-680-7453	Fax: 58-281-274-7900
Hubbell Int'l. Inc., Korea Branch	82-2-(0)2607-1363	Fax: 82-2-(0)2603-7386			